

AURORA

The *Motion-Transfer* Specialists



**ROD END & SPHERICAL BEARING
SUPPLEMENT TO CATALOG 319**

COMMERCIAL | MILITARY | AIRCRAFT



Contents

Page No.

Rod Ends and Spherical Bearings

HXAM-XE-10 & HXAB-XE-10 Series Male Rod Ends3

HXAM-XET-10 & HXAB-XET-10 Series Male Rod Ends 4

HXAW-XE-10 & HXAG-XE-10 Series Female Rod Ends5

HXAW-XET-10 & HXAG-XET-10 Series Female Rod Ends 6

ASM(K)-X-10 & ASB(K)-X-10 Series Male Rod Ends 7

ASW(K)-X-10 & ASG(K)-X-10 Series Female Rod Ends 8

ASXM(K) & ASXB(K) Series Male Rod Ends9

ASXM(K)-XT & ASXB(K)-XT Series Male Rod Ends 10

ASXW(K) & ASXG(K) Series Female Rod Ends 11

ASXW(K)-XT & ASXG(K)-XT Series Female Rod Ends 12

HAB-XE(G) Series Spherical Bearings..... 13

HAB-XET(G) Series Spherical Bearings 14

HIGH MISALIGNMENT SERIES MALE ROD ENDS

Corrosion Resistant - Precision

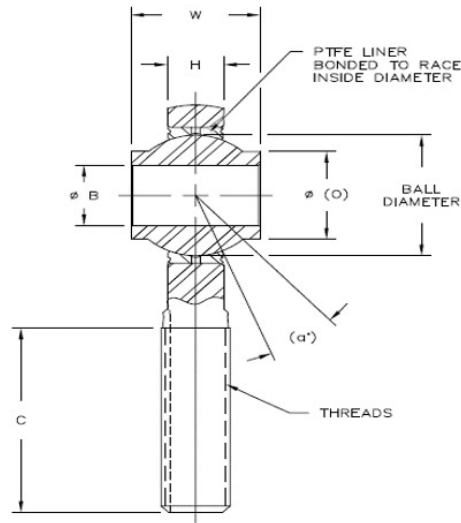
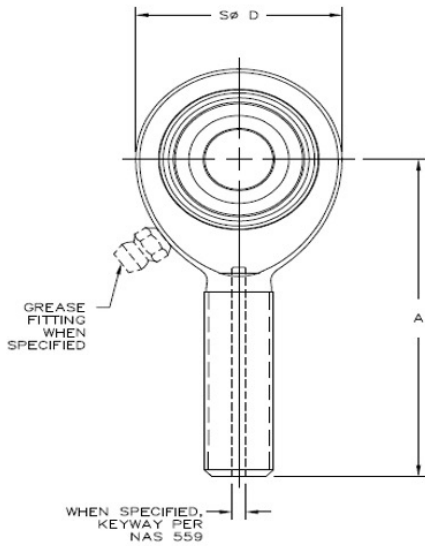

Body - 17-4 PH stainless steel, heat treated

Race - 17-4 PH stainless steel, heat treated

Ball - 440c stainless steel, heat treated, chrome plated (MFG. option)

When a keyway is required, specify by adding a K at the end of the part number.

Ex.: HXAM-6E-10K

Units are supplied without grease fittings. When grease fittings are required, specify by adding suffixes as designated.

Z Zerk type fitting Ex.: HXAM-5EZ-10

F Flush type fitting Ex.: HXAM-6EF-10

Load ratings apply only to rod ends without grease fittings. For load ratings with fittings, please consult our engineering department.

ROD END NO.		DIMENSIONS IN INCHES										a° Misalign. Angle Ref.	Radial Clearance In.	Ult. Static Radial Load Lbs.	Approx. Brg. Wt. Lbs.
Right Hand	Left Hand	B +.0000 -.0005	W +.000 -.005	H ±.005	A ±.010	D ±.010	O REF.	Ball Dia. Ref.	C ±.060	THREAD UNJF-3A					
HXAM-3E-10	HXAB-3E-10	.1900	.560	.337	1.562	.781	.301	.531	1.000	5/16-24	16	.002 Max.	5,482	.08	
HXAM-3E-11	HXAB-3E-11	.1900	.500	.220	1.500	.750	.319	.437	1.000	5/16-24	13		4,854	.06	
HXAM-4E-10	HXAB-4E-10	.2500	.593	.265	1.938	1.000	.390	.593	1.187	5/16-24	23		7,574	.11	
HXAM-5E-10	HXAB-5E-10	.3125	.813	.355	2.125	1.125	.512	.781	1.281	5/16-24	23		7,574	.18	
HXAM-5E-11	HXAB-5E-11	.3125	.625	.265	1.875	.875	.418	.593	1.062	5/16-24	16		5,817	.10	
HXAM-6E-10	HXAB-6E-10	.3750	.813	.355	2.125	1.125	.512	.781	1.281	3/8-24	23		9,151	.17	
HXAM-7E-10	HXAB-7E-10	.4375	.875	.355	2.437	1.312	.618	.875	1.500	7/16-20	22		13,824	.26	
HXAM-8E-10	HXAB-8E-10	.5000	.937	.411	2.625	1.500	.730	1.000	1.562	1/2-20	20		19,474	.40	
HXAM-10E-10	HXAB-10E-10	.6250	1.200	.577	2.875	1.750	.856	1.250	1.687	5/8-18	20		26,281	.63	
HXAM-12E-10	HXAB-12E-10	.7500	1.280	.630	3.375	2.000	.970	1.375	1.875	3/4-16	18		34,065	.87	
HXAM-14E-10	HXAB-14E-10	.8750	1.400	.635	3.750	2.200	1.140	1.531	2.000	7/8-14	18		35,670	1.01	
HXAM-16E-10	HXAB-16E-10	1.0000	1.875	.845	4.125	2.725	1.278	1.875	2.125	1 1/4-12	21		64,393	2.31	
HXAM-20E-10	HXAB-20E-10	1.2500	1.875	1.015	5.000	3.125	1.523	2.250	2.875	1 1/4-12	21		78,050	3.15	

timkenaurorabearing.com • Fax 630-859-0971



HIGH MISALIGNMENT SERIES MALE ROD ENDS

Corrosion Resistant - Precision - PTFE Lined

timkenaurorabearing.com • Fax 630-859-0971

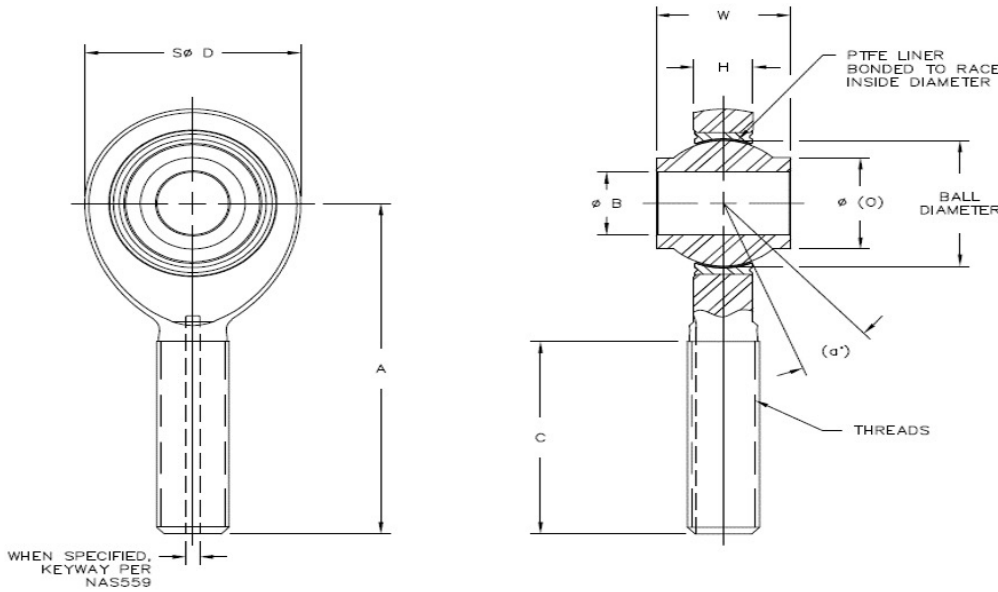

Body - 17-4 PH stainless steel, heat treated

Race - 17-4 PH stainless steel, heat treated

Ball - 440C stainless steel, heat treated, chrome plated (MFG. option)

Liner - (AT 3200) permanently bonded to race inside diameter

When a keyway is required, specify by adding a K at the end of the part number.

Ex.: HXAM-6ET-10K

ROD END NO.		DIMENSIONS IN INCHES										a° Misalign. Angle Ref.	No Load Rotational Breakway Torque In-Lbs.		Ult. Static Radial Load Lbs.	Approx. Brg. Wt. Lbs.
Right Hand	Left Hand	B	W	H	A	D	O	Ball Dia. Ref.	C	THREAD UNJF-3A	Min.		Max.			
		+0.000 -0.005	+0.000 -0.005	±.005	±.010	±.010	REF.	±.060								
HXAM-3ET-10	HXAB-3ET-10	.1900	.560	.337	1.562	.781	.301	.531	1.000	5/16-24	16	.5	6	5,482	.08	
HXAM-3ET-11	HXAB-3ET-11	.1900	.500	.220	1.500	.750	.319	.437	1.000	5/16-24	13	.5	6	4,854	.06	
HXAM-4ET-10	HXAB-4ET-10	.2500	.593	.265	1.938	1.000	.390	.593	1.187	5/16-24	23	1	15	7,574	.11	
HXAM-5ET-10	HXAB-5ET-10	.3125	.813	.355	2.125	1.125	.512	.781	1.281	5/16-24	23	1	15	7,574	.18	
HXAM-5ET-11	HXAB-5ET-11	.3125	.625	.265	1.875	.875	.418	.593	1.062	5/16-24	16	1	15	5,817	.10	
HXAM-6ET-10	HXAB-6ET-10	.3750	.813	.355	2.125	1.125	.512	.781	1.281	3/8-24	23	1	15	9,151	.17	
HXAM-7ET-10	HXAB-7ET-10	.4375	.875	.355	2.437	1.312	.618	.875	1.500	7/16-20	22	1	15	13,824	.26	
HXAM-8ET-10	HXAB-8ET-10	.5000	.937	.411	2.625	1.500	.730	1.000	1.562	1/2-20	20	1	15	19,474	.40	
HXAM-10ET-10	HXAB-10ET-10	.6250	1.200	.577	2.875	1.750	.856	1.250	1.687	5/8-18	20	1	15	26,281	.63	
HXAM-12ET-10	HXAB-12ET-10	.7500	1.280	.630	3.375	2.000	.970	1.375	1.875	3/4-16	18	1	24	34,065	.87	
HXAM-14ET-10	HXAB-14ET-10	.8750	1.400	.635	3.750	2.200	1.140	1.531	2.000	7/8-14	18	1	24	35,670	1.01	
HXAM-16ET-10	HXAB-16ET-10	1.0000	1.875	.845	4.125	2.725	1.278	1.875	2.125	1 1/4-12	21	1	24	64,393	2.31	
HXAM-20ET-10	HXAB-20ET-10	1.2500	1.875	1.015	5.000	3.125	1.523	2.250	2.875	1 1/4-12	21	1	24	78,050	3.15	

HIGH MISALIGNMENT SERIES FEMALE ROD ENDS

Corrosion Resistant - Precision

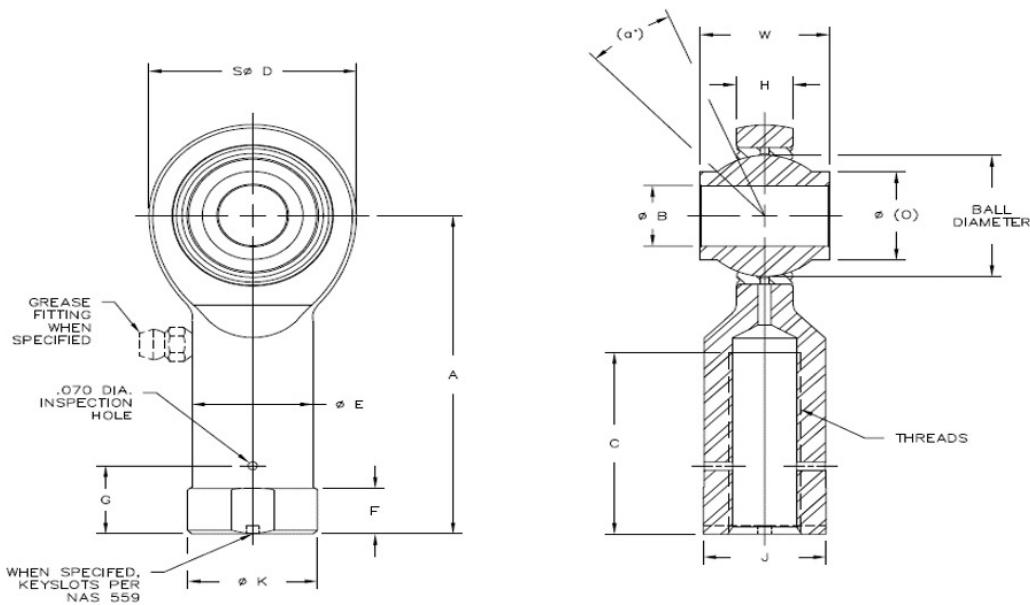

Body - 17-4 PH stainless steel, heat treated

Race - 17-4 PH stainless steel, heat treated

Ball - 440C stainless steel, heat treated, chrome plated (MFG. option)

When a keyway is required, specify by adding a K at the end of the part number.

Ex.: HXAW-6E-10K

Units are supplied without grease fittings. When grease fittings are required, specify by adding suffixes as designated.

Z Zerk type fitting Ex.: HXAW-5EZ-10

F Flush type fitting Ex.: HXAW-6EF-10

Load ratings apply only to rod ends without grease fittings. For load ratings with fittings, please consult our engineering department.

timkenaurorabearing.com • Fax 630-859-0971

ROD END NO.		DIMENSIONS IN INCHES														a ⁹ Misalign. Angle Ref.	Radial Clearance In	Ult. Static Radial Load Lbs.	Approx. Brg. Wt. Lbs.
Right Hand	Left Hand	B +.0000 -.0005	W +.000 -.005	H ±.005	A ±.010	D ±.010	O REF.	Ball Dia. Ref.	C ±.060	THREAD UNJF-3B	E ±.010	K REF	F +.010 -.062	G ±.020	J ±.010				
HXAW-3E-10	HXAG-3E-10	.1900	.560	.337	1.625	.781	.301	.531	.750	5/16-24	.500	.562	.250	.375	.515	16	.002 Max.	5,482	.08
HXAW-3E-11	HXAG-3E-11	.1900	.500	.220	1.375	.750	.319	.437	.750	5/16-24	.437	.500	.250	.375	.452	13		4,854	.06
HXAW-4E-10	HXAG-4E-10	.2500	.593	.265	1.625	1.000	.390	.593	.937	5/16-24	.562	.625	.250	.375	.577	23		8,509	.11
HXAW-5E-10	HXAG-5E-10	.3125	.813	.355	1.812	1.125	.512	.781	1.062	5/16-24	.625	.688	.250	.375	.640	23		9,151	.18
HXAW-5E-11	HXAG-5E-11	.3125	.625	.265	1.375	.875	.418	.593	.750	5/16-24	.437	.500	.250	.375	.452	16		5,817	.10
HXAW-6E-10	HXAG-6E-10	.3750	.813	.355	1.812	1.125	.512	.781	1.062	3/8-24	.625	.688	.250	.437	.640	23		9,151	.17
HXAW-7E-10	HXAG-7E-10	.4375	.875	.355	2.125	1.312	.618	.875	1.125	7/16-20	.750	.812	.250	.500	.765	22		13,824	.26
HXAW-8E-10	HXAG-8E-10	.5000	.937	.411	2.625	1.500	.730	1.000	1.500	1/2-20	.875	.938	.375	.562	.890	20		19,474	.40
HXAW-10E-10	HXAG-10E-10	.6250	1.200	.577	2.875	1.750	.856	1.250	1.750	5/8-18	1.000	1.125	.375	.687	1.015	20		26,281	.63
HXAW-12E-10	HXAG-12E-10	.7500	1.280	.630	3.375	2.000	.970	1.375	1.875	3/4-16	1.125	1.250	.500	.812	1.140	18		34,065	.87
HXAW-14E-10	HXAG-14E-10	.8750	1.400	.635	3.750	2.200	1.140	1.531	2.000	7/8-14	1.125	1.250	.500	.937	1.140	18		35,670	1.01
HXAW-16E-10	HXAG-16E-10	1.0000	1.875	.845	4.125	2.725	1.278	1.875	2.125	1 1/4-12	1.688	1.813	.562	1.312	1.703	21		63,207	2.31
HXAW-20E-10	HXAG-20E-10	1.2500	1.875	1.015	5.000	3.125	1.523	2.250	3.125	1 1/4-12	1.688	1.813	.562	1.312	1.703	21		78,050	3.15



HIGH MISALIGNMENT SERIES FEMALE ROD ENDS

Corrosion Resistant - Precision - PTFE Lined

Body - 17-4 PH stainless steel, heat treated

Race - 17-4 PH stainless steel, heat treated

Ball - 440C stainless steel, heat treated, chrome plated (MFG. option)

Liner - (AT 3200) permanently bonded to race inside diameter

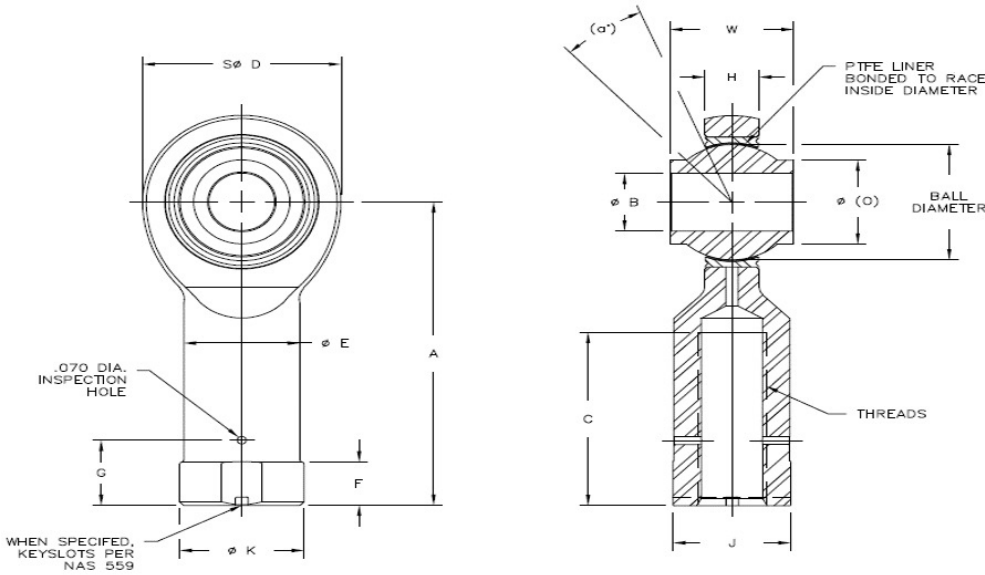

When a keyway is required, specify by adding a K at the end of the part number.
Ex.: HXAW-6ET-10K

timkenaurorabearing.com • Fax 630-859-0971

ROD END NO.		DIMENSIONS IN INCHES														a° Misalign. Angle Ref.	No Load Rotational Breakway Torque In-Lbs.		Ult. Static Radial Load Lbs.	Approx. Brg. Wt. Lbs.
Right Hand	Left Hand	B +.0000 -.0005	W +.000 -.005	H ±.005	A ±.010	D ±.010	O REF.	Ball Dia. Ref.	C ±.060	THREAD UNJF-3B	E ±.010	K REF.	F +.010 -.062	G ±.020	J ±.010		Min.	Max.		
HXAW-3ET-10	HXAG-3ET-10	.1900	.560	.337	1.625	.781	.301	.531	.750	5/16-24	.500	.562	.250	.375	.515	16	.5	6	5,482	.08
HXAW-3ET-11	HXAG-3ET-11	.1900	.500	.220	1.375	.750	.319	.437	.750	5/16-24	.437	.500	.250	.375	.452	13	.5	6	4,854	.06
HXAW-4ET-10	HXAG-4ET-10	.2500	.593	.265	1.625	1.000	.390	.593	.937	5/16-24	.562	.625	.250	.375	.577	23	1	15	8,509	.11
HXAW-5ET-10	HXAG-5ET-10	.3125	.813	.355	1.812	1.125	.512	.781	1.062	5/16-24	.625	.688	.250	.375	.640	23	1	15	9,151	.18
HXAW-5ET-11	HXAG-5ET-11	.3125	.625	.265	1.375	.875	.418	.593	.750	5/16-24	.437	.500	.250	.375	.452	16	1	15	5,817	.10
HXAW-6ET-10	HXAG-6ET-10	.3750	.813	.355	1.812	1.125	.512	.781	1.062	3/8-24	.625	.688	.250	.437	.640	23	1	15	9,151	.17
HXAW-7ET-10	HXAG-7ET-10	.4375	.875	.355	2.125	1.312	.618	.875	1.125	7/16-20	.750	.812	.250	.500	.765	22	1	15	13,824	.26
HXAW-8ET-10	HXAG-8ET-10	.5000	.937	.411	2.625	1.500	.730	1.000	1.500	1/2-20	.875	.938	.375	.562	.890	20	1	15	19,474	.40
HXAW-10ET-10	HXAG-10ET-10	.6250	1.200	.577	2.875	1.750	.856	1.250	1.750	5/8-18	1.000	1.125	.375	.687	1.015	20	1	15	26,281	.63
HXAW-12ET-10	HXAG-12ET-10	.7500	1.280	.630	3.375	2.000	.970	1.375	1.875	3/4-16	1.125	1.250	.500	.812	1.140	18	1	24	34,065	.87
HXAW-14ET-10	HXAG-14ET-10	.8750	1.400	.635	3.750	2.200	1.140	1.531	2.000	7/8-14	1.125	1.250	.500	.937	1.140	18	1	24	35,670	1.01
HXAW-16ET-10	HXAG-16ET-10	1.0000	1.875	.845	4.125	2.725	1.278	1.875	2.125	1 1/4-12	1.688	1.813	.562	1.312	1.703	21	1	24	63,207	2.31
HXAW-20ET-10	HXAG-20ET-10	1.2500	1.875	1.015	5.000	3.125	1.523	2.250	3.125	1 1/4-12	1.688	1.813	.562	1.312	1.703	21	1	24	78,050	3.15

ASM-X-10 & ASB-X-10 MALE ROD ENDS

Aerospace Series - Corrosion Resistant

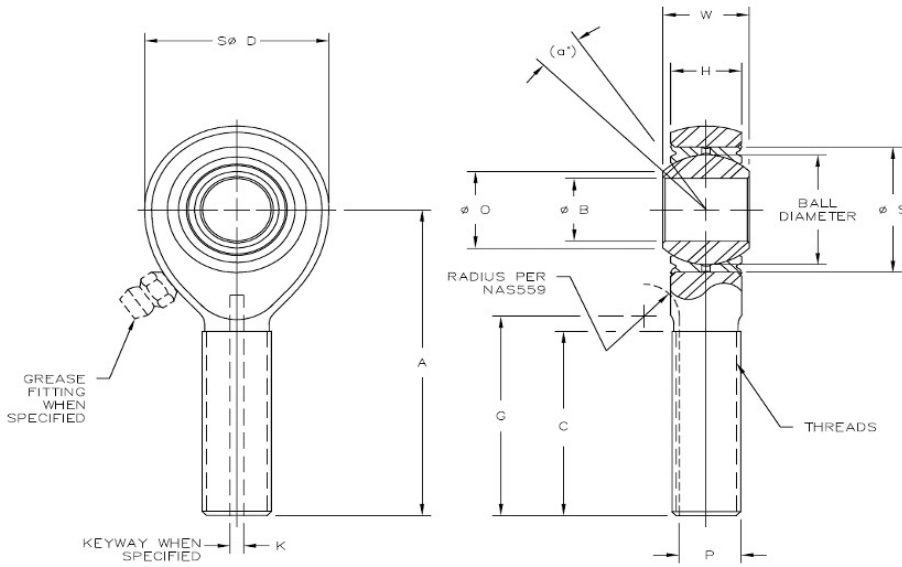

Body - 17-4 PH stainless steel, heat treated

Race - 17-4 PH stainless steel, heat treated

Ball - 440C stainless steel, heat treated, chrome plated (MFG. option)

timkenaurorabearing.com • Fax 630-859-0971

ROD END NO.		DIMENSIONS IN INCHES													a° Misalign. Angle Min.	Radial Clearance In	Ult. Static Radial Load Lbs.	Axial Proof Load Lbs.	Approx. Brg. Wt. Lbs.
Right Hand	Left Hand	B +.0000 -.0005	W +.000 -.002	H ±.005	A ±.010	D ±.010	O MIN.	S Max. Housing I.D.	Ball Dia. Ref.	G +.000 -.020	K +.005 -.000	P +.000 -.005	C ±.031	Thread UNJF-3A					
ASM-3-10	ASB-3-10	.1900	.437	.337	1.562	.806	.30	.6250	.531	.980	.062	.268	.968	5/16-24	15	.002 Max.	6,688	1,000	.072
ASM-4-10	ASB-4-10	.2500	.437	.337	1.562	.806	.30	.6250	.531	.980	.062	.268	.968	5/16-24	15		6,688	1,000	.072
ASM-5-10	ASB-5-10	.3125	.437	.327	1.875	.900	.36	.6875	.593	1.270	.062	.268	1.187	5/16-24	14		7,574	1,100	.087
ASM-6-10	ASB-6-10	.3750	.500	.416	1.938	1.025	.47	.8125	.687	1.235	.093	.319	1.187	3/8-24	8		9,681	1,660	.136
ASM-7-10	ASB-7-10	.4375	.562	.452	2.125	1.150	.54	.9062	.781	1.402	.093	.383	1.281	7/16-20	10		12,415	1,850	.183
ASM-8-10	ASB-8-10	.5000	.625	.515	2.438	1.337	.61	1.0000	.875	1.589	.093	.445	1.468	1/2-20	9		20,576	2,040	.278
ASM-10-10	ASB-10-10	.6250	.750	.577	2.625	1.525	.75	1.1875	1.062	1.683	.125	.541	1.562	5/8-18	12		22,891	2,430	.424
ASM-12-10	ASB-12-10	.7500	.875	.640	2.875	1.775	.85	1.3750	1.250	1.808	.125	.663	1.687	3/4-16	13		30,327	2,810	.639
ASM-14-10	ASB-14-10	.8750	.875	.765	3.375	2.025	1.00	1.6250	1.375	2.121	.156	.777	2.000	7/8-14	6		35,391	3,320	.963
ASM-16-10	ASB-16-10	1.0000	1.375	1.015	4.125	2.775	1.27	2.1250	1.875	2.464	.187	1.136	2.343	1 1/4-12	12		80,547	4,340	2.546

AS M - 6 - 10
 -10 DESIGNATES A 17-4 PH STAINLESS STEEL BODY
 " " - NO CODE - NO GREASE FITTING
 "F" = FLUSH TYPE GREASE FITTING
 "Z" = ZERK TYPE GREASE FITTING
 NOMINAL BORE DIAMETER IN SIXTEENTH OF AN INCH INCREMENTS
 " " - NO CODE - NO KEYWAY
 "K" = KEYWAY
 "M" = RIGHT HAND THREAD
 "B" = LEFT HAND THREAD
 BASIC AURORA ROD END PART NUMBER



ASW-X-10 & ASG-X-10 FEMALE ROD ENDS

Aerospace Series - Corrosion Resistant

timkenaurorabearing.com • Fax 630-859-0971

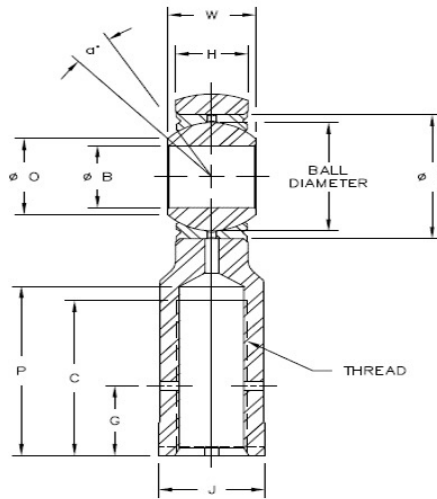
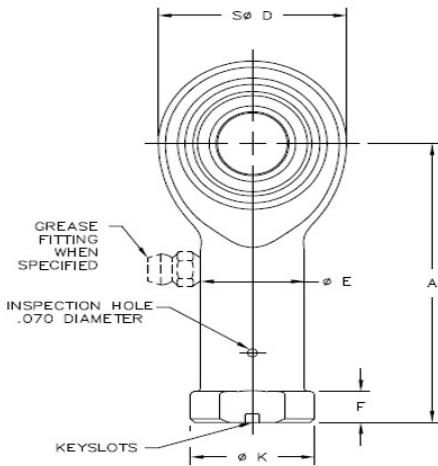

Body - 17-4 PH stainless steel, heat treated

Race - 17-4 PH stainless steel, heat treated

Ball - 440C stainless steel, heat treated, chrome plated (MFG. option)

ROD END NO.		DIMENSIONS IN INCHES															a° Misalign. Angle Min.	Radial Clearance In	Ult. Static Radial Load Lbs.	Axial Proof Load Lbs.	Approx. Brg. Wt. Lbs.
Right Hand	Left Hand	B +.0000 -.0005	W +.000 -.002	H ±.005	A ±.010	D ±.010	O MIN.	S Max. Housing I.D.	E ±.010	K Ref.	J ±.010	F +.010 -.062	Ball Dia. Ref.	P Max.	C Min.	Thread UNJF-3B					
ASW-3-10	ASG-3-10	.1900	.437	.337	1.375	.806	.30	.6250	.422	.500	.437	.188	.531	.875	.750	5/16-24	15	.002 Max.	6,688	1,000	.080
ASW-4-10	ASG-4-10	.2500	.437	.337	1.469	.806	.30	.6250	.422	.500	.437	.188	.531	.875	.750	5/16-24	15		6,688	1,000	.084
ASW-5-10	ASG-5-10	.3125	.437	.327	1.625	.900	.36	.6875	.485	.580	.500	.250	.593	1.000	.875	3/8-24	14		8,063	1,100	.102
ASW-6-10	ASG-6-10	.3750	.500	.416	1.812	1.025	.47	.8125	.547	.660	.562	.250	.687	1.125	1.000	3/8-24	8		9,681	1,660	.161
ASW-7-10	ASG-7-10	.4375	.562	.452	2.000	1.150	.54	.9062	.610	.720	.625	.250	.781	1.250	1.125	7/16-20	10		12,415	1,850	.212
ASW-8-10	ASG-8-10	.5000	.625	.515	2.250	1.337	.61	1.0000	.735	.880	.750	.250	.875	1.375	1.250	1/2-20	9		20,576	2,040	.325
ASW-10-10	ASG-10-10	.6250	.750	.577	2.500	1.525	.75	1.1875	.860	1.020	.875	.375	1.062	1.500	1.375	5/8-18	12		22,891	2,430	.481
ASW-12-10	ASG-12-10	.7500	.875	.640	2.875	1.775	.85	1.3750	.985	1.160	1.000	.375	1.250	1.750	1.625	3/4-16	13		30,327	2,810	.673
ASW-14-10	ASG-14-10	.8750	.875	.765	3.375	2.025	1.00	1.6250	1.110	1.300	1.125	.500	1.375	2.062	1.875	7/8-14	6		35,391	3,320	.963
ASW-16-10	ASG-16-10	1.0000	1.375	1.015	4.125	2.775	1.27	2.1250	1.688	2.020	1.750	.563	1.875	2.312	2.125	1 1/4-12	12		80,547	4,340	2.717

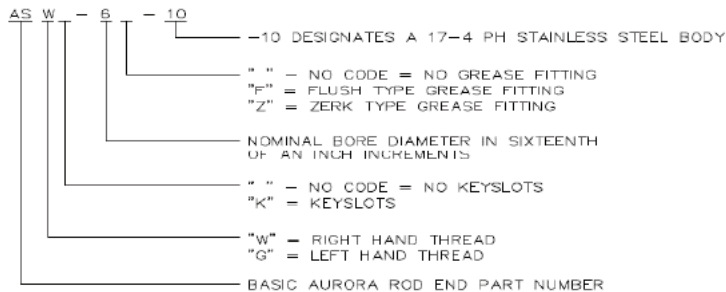

ASXM & ASXB MALE ROD ENDS

Aerospace Series - Heavy Duty Shank



timkenaurorabearing.com • Fax 630-859-0971

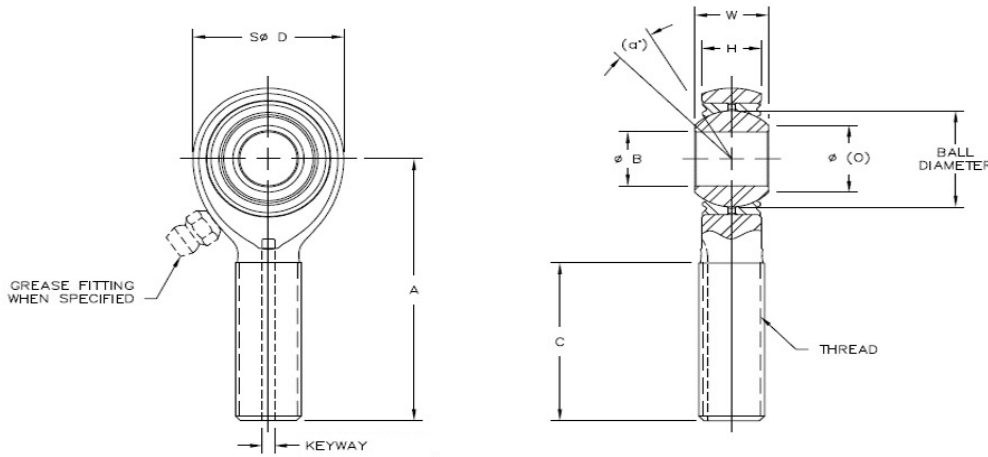

Body - 4340 alloy steel, heat treated, cadmium plated

Race - 4130 alloy steel, heat treated, cadmium plated

Ball - 52100 alloy steel, heat treated, chrome plated

ROD END NO.		DIMENSIONS IN INCHES										a° Misalign. Angle Ref.	Radial Clearance In	Ult. Static Radial Load Lbs.		Approx. Brg. Wt. Lbs.
Right Hand	Left Hand	B +0.000 -0.005	W +0.000 -0.005	H ±0.005	A ±0.010	D ±0.010	O REF.	Ball Dia. Ref.	C +0.031 -0.031	THREAD UNF-3A	4340 Steel			17-4 Stainless Steel		
ASXM-4	ASXB-4	.2500	.375	.337	1.562	.806	.375	.531	.968	5/16-24	5	.002 Max.	7,356	6,668	.07	
ASXM-5	ASXB-5	.3125	.437	.327	1.875	.900	.401	.593	1.187	3/8-24	14		8,895	8,063	.10	
ASXM-6	ASXB-6	.3750	.500	.416	1.938	1.025	.471	.687	1.187	7/16-20	9		10,680	9,681	.14	
ASXM-7	ASXB-7	.4375	.562	.452	2.125	1.150	.542	.781	1.281	1/2-20	10		13,697	12,415	.21	
ASXM-8	ASXB-8	.5000	.625	.515	2.438	1.337	.612	.875	1.468	5/8-18	9		22,700	20,576	.33	
ASXM-10	ASXB-10	.6250	.750	.577	2.625	1.525	.752	1.062	1.562	3/4-16	12		25,254	22,891	.48	
ASXM-12	ASXB-12	.7500	.875	.640	2.875	1.775	.892	1.250	1.687	7/8-14	13		33,457	30,327	.73	

ASX M K - B F - 10

- " " - NO CODE = 4340 STEEL CADMIUM PLATED BODY, 52100 STEEL CHROME PLATED BALL, 4130 STEEL CADMIUM PLATED RACE
- "-1" - 4340 STEEL CADMIUM PLATED BODY, 52100 STEEL CHROME PLATED BALL, 17-4 PH STAINLESS STEEL RACE
- "-2" - 4340 STEEL CADMIUM PLATED BODY, 52100 STEEL CHROME PLATED BALL ALUMINUM BRONZE CADMIUM PLATED RACE
- "-10" - 17-4 PH STAINLESS STEEL BODY AND RACE, 440C STAINLESS STEEL BALL
- " " - NO CODE = NO GREASE FITTING
- "F" = FLUSH TYPE GREASE FITTING
- "Z" = ZERK TYPE GREASE FITTING
- "B" = 440C STAINLESS STEEL CHROME PLATED BALL (ONLY AVAILABLE WITH -10)
- NOMINAL BORE DIAMETER IN SIXTEENTH OF AN INCH INCREMENTS
- " " - NO CODE = NO KEYWAY
- "K" = KEYWAY
- "M" = RIGHT HAND THREAD
- "B" = LEFT HAND THREAD
- BASIC AURORA ROD END PART NUMBER



ASXM-T & ASXB-T MALE ROD ENDS

Aerospace Series - Heavy Duty Shank - PTFE Lined

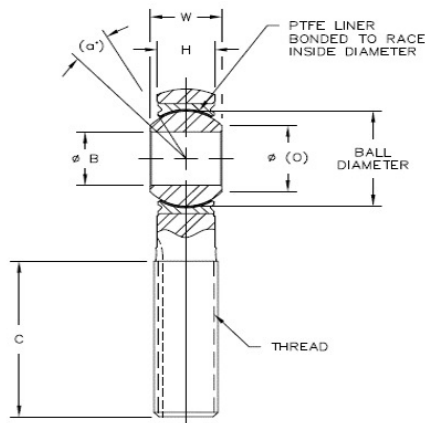
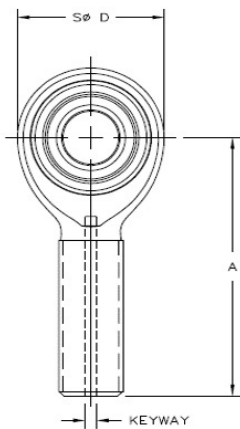

Body - 4340 alloy steel, heat treated, cadmium plated

Race - 17-4 PH stainless steel, heat treated

Ball - 440C stainless steel, heat treated, chrome plated (MFG. option)

Liner - (AT 3200) permanently bonded to race inside diameter

timkenaurorabearing.com • Fax 630-859-0971

ROD END NO.		DIMENSIONS IN INCHES									a ^o Misalign. Angle Ref.	No Load Rotational Breakway Torque In-Lbs.		Ult. Static Radial Load Lbs.		Axial Proof Load Lbs.	Approx. Brg. Wt. Lbs.
Right Hand	Left Hand	B	W	H	A	D	O	Ball Dia. Ref.	C	THREAD UNF-3A		Min.	Max.	4340 Steel	17-4 Stainless Steel		
		+0.000 -.0005	+0.000 -.002	±.005	±.010	±.010	REF.	Ref.	+0.031 -.031								
ASXM-4T	ASXB-4T	.2500	.375	.337	1.562	.806	.375	.531	.968	5/16-24	5	.5	6	7,356	6,668	1,000	.07
ASXM-5T	ASXB-5T	.3125	.437	.327	1.875	.900	.401	.593	1.187	3/8-24	14	1	10	8,895	8,063	1,100	.10
ASXM-6T	ASXB-6T	.3750	.500	.416	1.938	1.025	.471	.687	1.187	7/16-20	9	1	10	10,680	9,681	1,660	.14
ASXM-7T	ASXB-7T	.4375	.562	.452	2.125	1.150	.542	.781	1.281	1/2-20	10	1	10	13,697	12,415	1,850	.21
ASXM-8T	ASXB-8T	.5000	.625	.515	2.438	1.337	.612	.875	1.468	5/8-18	9	1	10	22,700	20,576	2,040	.33
ASXM-10T	ASXB-10T	.6250	.750	.577	2.625	1.525	.752	1.062	1.562	3/4-16	12	1	10	25,254	22,891	2,430	.48
ASXM-12T	ASXB-12T	.7500	.875	.640	2.875	1.775	.892	1.250	1.687	7/8-14	13	1	10	33,457	30,327	2,810	.73

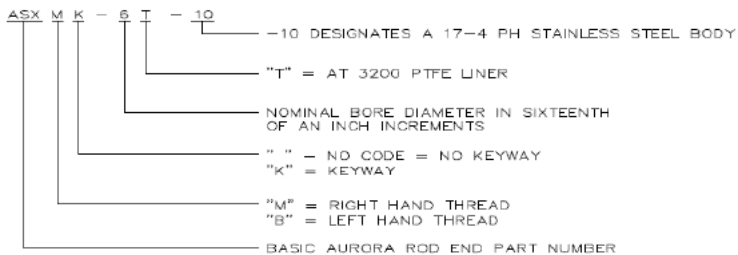

ASXW & ASXG FEMALE ROD ENDS

Aerospace Series

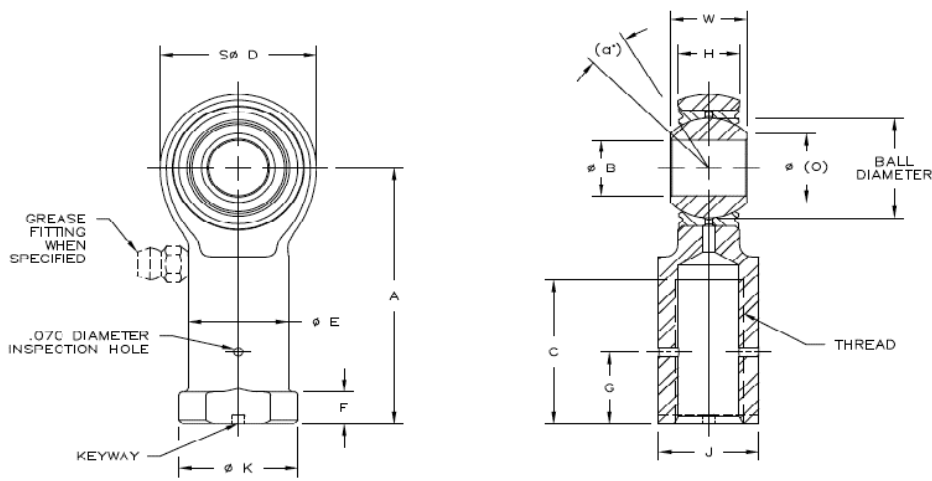

Body - 4340 alloy steel, heat treated, cadmium plated

Race - 4130 alloy steel, heat treated, cadmium plated

Ball - 52100 alloy steel, heat treated, chrome plated

timkenaurorabearing.com • Fax 630-859-0971

ROD END NO.		DIMENSIONS IN INCHES													a° Misalign. Angle Ref.	Radial Clearance In	Ult. Static Radial Load Lbs.		Approx. Brg. Wt. Lbs.
Right Hand	Left Hand	B +.0000 -.0005	W +.000 -.002	H ±.005	A ±.010	D ±.010	O REF.	E ±.010	K Ref.	J ±.010	F +.010 -.062	Ball Dia. Ref.	C Min.	Thread UNJF-3B			4340 Steel	17-4 Stainless Steel	
ASXW-4	ASXG-4	.2500	.375	.337	1.469	.806	.375	.485	.562	.500	.188	.531	.750	5/16-24	5	.002 Max.	7,356	6,668	.084
ASXW-5	ASXG-5	.3125	.437	.327	1.625	.900	.401	.547	.625	.562	.250	.593	.875	3/8-24	14		8,895	8,063	.102
ASXW-6	ASXG-6	.3750	.500	.416	1.812	1.025	.471	.610	.687	.625	.250	.687	1.000	7/16-20	9		10,680	9,681	.160
ASXW-7	ASXG-7	.4375	.562	.452	2.000	1.150	.542	.735	.875	.750	.250	.781	1.125	1/2-20	10		13,697	12,415	.230
ASXW-8	ASXG-8	.5000	.625	.515	2.225	1.337	.612	.860	1.000	.875	.250	.875	1.250	5/8-18	9		22,700	20,576	.340
ASXW-10	ASXG-10	.6250	.750	.577	2.500	1.525	.752	.985	1.125	1.000	.375	1.062	1.375	3/4-16	12		25,254	22,891	.490
ASXW-12	ASXG-12	.7500	.875	.640	2.875	1.775	.892	1.110	1.250	1.125	.375	1.250	1.625	7/8-14	13		33,457	30,327	.740

ASX W K - E F - 10

- " " - NO CODE = 4340 STEEL CADMIUM PLATED BODY, 52100 STEEL CHROME PLATED BALL, 4130 STEEL CADMIUM PLATED RACE.
- "-1" - 4340 STEEL CADMIUM PLATED BODY, 52100 STEEL CHROME PLATED BALL, 17-4 PH STAINLESS STEEL RACE.
- "-2" - 4340 STEEL CADMIUM PLATED BODY, 52100 STEEL CHROME PLATED BALL, ALUMINUM BRONZE CADMIUM PLATED RACE.
- "-10" - 17-4 PH STAINLESS STEEL BODY AND RACE, 440C STAINLESS STEEL BALL
- " " - NO CODE = NO GREASE FITTING
- "F" = FLUSH TYPE GREASE FITTING
- "Z" = ZERK TYPE GREASE FITTING
- "P" = 440C STAINLESS STEEL CHROME PLATED BALL (ONLY AVAILABLE WITH -10)
- NOMINAL BORE DIAMETER IN SIXTEENTH OF AN INCH INCREMENTS
- " " - NO CODE = NO KEYSLOTS
- "K" = KEYSLOTS
- "W" = RIGHT HAND THREAD
- "G" = LEFT HAND THREAD

BASIC AURORA ROD END PART NUMBER



ASXW-T & ASXG-T FEMALE ROD ENDS

Aerospace Series - PTFE Lined

timkenaurorabearing.com • Fax 630-859-0971

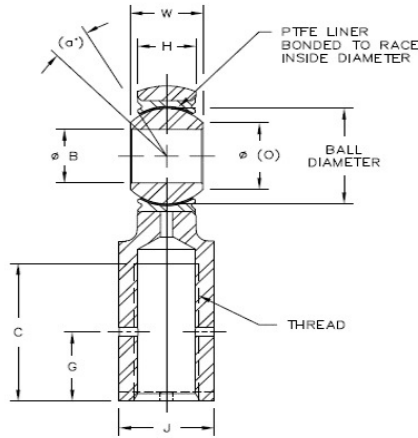
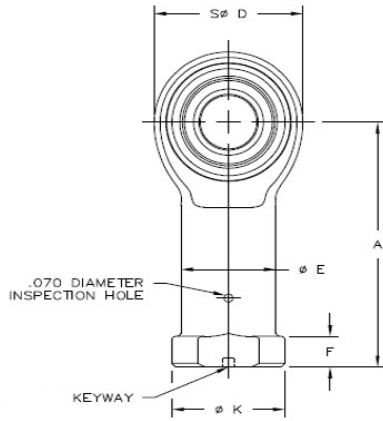

Body - 4340 alloy steel, heat treated, cadmium plated

Race - 17-4 PH stainless steel, heat treated

Ball - 440C stainless steel, heat treated, chrome plated (MFG. option)

Liner - (AT 3200) permanently bonded to race inside diameter

ROD END NO.		DIMENSIONS IN INCHES														a° Misalign. Angle Ref.	No Load Breakway Torque In-Lbs.	Ult. Static Radial Load Lbs.		Axial Proof Load Lbs.	Approx. Brg. Wt. Lbs.	
Right Hand	Left Hand	B	W	H	A	D	O	E	K	J	F	Ball Dia. Ref.	C	Thread UNJF-3B	Min.			Max.	4340 Steel			17-4 Stainless Steel
		+0.000 -0.0005	+0.000 -0.002	±.005	±.010	±.010	Ref.	±.010	Ref.	±.010	+0.010 -0.062		Min.									
ASXW-4T	ASXG-4T	.2500	.375	.337	1.469	.806	.375	.485	.562	.500	.188	.531	.750	5/16-24	5	.5	6	7,356	6,668	1,000	.084	
ASXW-5T	ASXG-5T	.3125	.437	.327	1.625	.900	.401	.547	.625	.562	.250	.593	.875	3/8-24	14	1	10	8,895	8,063	1,100	.102	
ASXW-6T	ASXG-6T	.3750	.500	.416	1.812	1.025	.471	.610	.687	.625	.250	.687	1.000	7/16-20	9	1	10	10,680	9,681	1,660	.160	
ASXW-7T	ASXG-7T	.4375	.562	.452	2.000	1.150	.542	.735	.875	.750	.250	.781	1.125	1/2-20	10	1	10	13,697	12,415	1,850	.230	
ASXW-8T	ASXG-8T	.5000	.625	.515	2.250	1.337	.612	.860	1.000	.875	.250	.875	1.250	5/8-18	9	1	10	22,700	20,576	2,040	.340	
ASXW-10T	ASXG-10T	.6250	.750	.577	2.500	1.525	.752	.985	1.125	1.000	.375	1.062	1.375	3/4-16	12	1	10	25,254	22,891	2,430	.490	
ASXW-12T	ASXG-12T	.7500	.875	.640	2.875	1.775	.892	1.110	1.250	1.125	.375	1.250	1.625	7/8-14	13	1	10	33,457	30,327	2,810	.740	

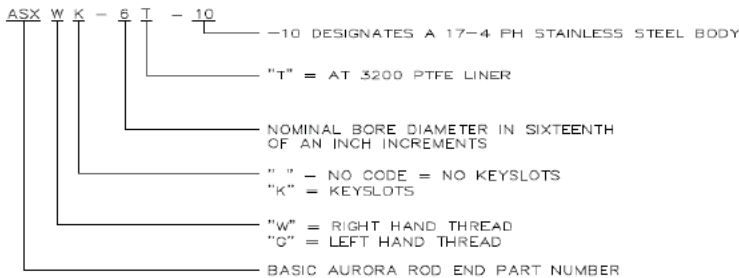

HIGH MISALIGNMENT SERIES SPHERICAL BEARINGS

Corrosion Resistant



Race - 17-4 PH stainless steel, heat treated



Ball - 440C stainless steel, heat treated, chrome plated (MFG. option)

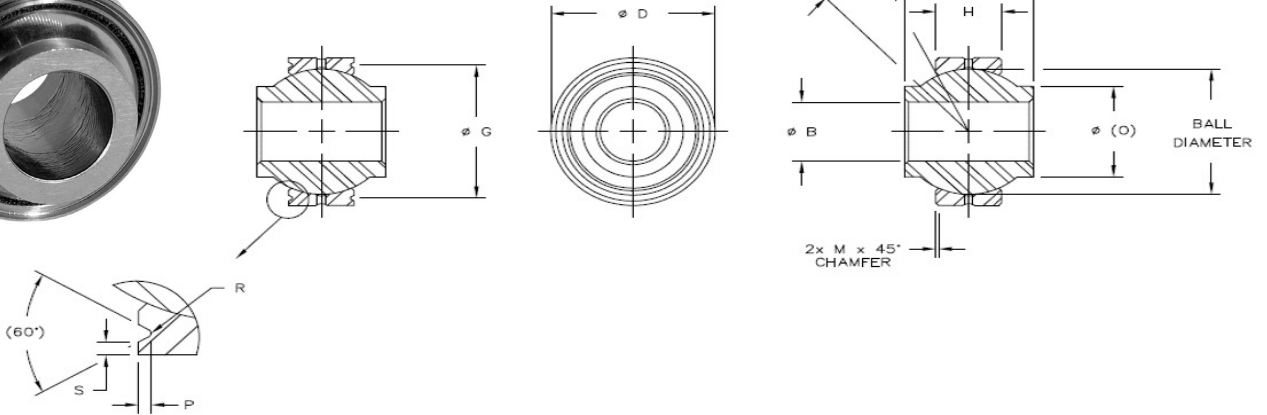

timkenaurorabearing.com • Fax 630-859-0971

BEARING NO.		DIMENSIONS IN INCHES											a ^e Misalign. Angle REF	Radial Clearance In	RADIAL STATIC LIMIT LOAD CAPACITY Lbs.	APPROX. BEARING WEIGHT Lbs.
Plain	Grooved	B +.0000 -.0005	D ±.0000 -.0005	W +.000 -.005	H ±.005	M Ref.	O Ref.	P +.000 -.010	S Min.	G +.000 -.008	R +.002 -.005	Ball Dia. Ref.				
HAB-3E-3	HAB-3EG-3	.1900	.5625	.500	.210	.010	.319	.025	.010	.494	.010	.437	13	.002 Max.	6,334	.02
HAB-4E	HAB-4EG	.2500	.7400	.593	.255	.010	.390	.025	.010	.674	.010	.593	23		10,564	.04
HAB-5E-4	HAB-5EG-4	.3125	.6875	.625	.255	.010	.418	.025	.010	.629	.010	.593	18		10,564	.03
HAB-6E	HAB-6EG	.3750	.9060	.813	.345	.020	.512	.025	.010	.840	.010	.781	23		18,881	.07
HAB-7E	HAB-7EG	.4375	1.0000	.875	.345	.020	.618	.025	.010	.934	.010	.875	21		21,302	.10
HAB-8E	HAB-8EG	.5000	1.1250	.937	.401	.020	.730	.025	.010	1.059	.010	1.000	19		28,326	.16
HAB-10E	HAB-10EG	.6250	1.3750	1.200	.567	.020	.856	.035	.020	1.279	.015	1.250	19		49,837	.25
HAB-12E	HAB-12EG	.7500	1.5625	1.280	.620	.030	.970	.035	.020	1.467	.015	1.375	18		60,013	.32
HAB-14E	HAB-14EG	.8750	1.7500	1.400	.625	.030	1.140	.035	.020	1.654	.015	1.531	17		67,810	.43
HAB-16E	HAB-16EG	1.0000	2.1250	1.875	.835	.030	1.278	.055	.020	2.000	.015	1.875	20		110,530	.83
HAB-18E	HAB-18EG	1.1250	2.3125	1.875	.942	.030	1.400	.055	.020	2.188	.015	2.062	20		136,957	1.10
HAB-20E	HAB-20EG	1.2500	2.5000	1.875	1.005	.030	1.523	.055	.020	2.375	.015	2.250	21		159,756	1.32
HAB-22E	HAB-22EG	1.3750	2.7500	2.125	1.097	.030	1.670	.055	.020	2.625	.015	2.500	22		194,078	1.80
HAB-24E	HAB-24EG	1.5000	3.0000	2.250	1.175	.030	1.800	.055	.020	2.875	.015	2.672	21		222,208	2.22



HIGH MISALIGNMENT SERIES SPHERICAL BEARINGS

Corrosion Resistant- PTFE Lined



Race - 17-4 PH stainless steel, heat treated

Ball - 440C stainless steel, heat treated, chrome plated (MFG. option)

Liner - (AT 3200) Permanently bonded to race inside diameter

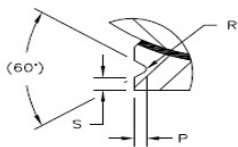
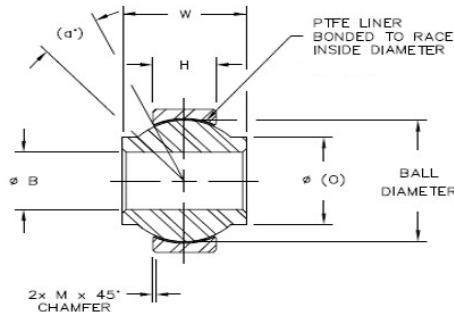
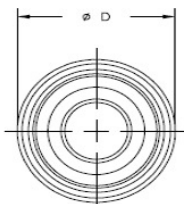
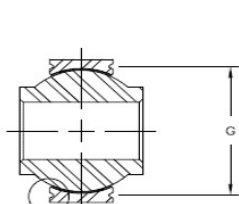

timkenaurorabearing.com • Fax 630-859-0971

BEARING NO.		DIMENSIONS IN INCHES											a° Misalign. Angle REF	NO-LOAD BREAKAWAY TORQUE (IN-LBS)		RADIAL STATIC LIMIT LOAD CAPACITY Lbs.	APPROX. BEARING WEIGHT Lbs.
Plain	Grooved	B +.0000 -.0005	D ±.0000 -.0005	W +.000 -.005	H ±.005	M Ref.	O Ref.	P +.000 -.010	S Min.	G +.000 -.008	R +.002 -.005	Ball Dia. Ref.		Min.	Max.		
HAB-3ET-3	HAB-3ETG-3	.1900	.5625	.500	.210	.010	.319	.025	.010	.494	.010	.437	13	.25	5	6,334	.02
HAB-4ET	HAB-4ETG	.2500	.7400	.593	.255	.010	.390	.025	.010	.674	.010	.593	23	.25	5	10,564	.04
HAB-5ET-4	HAB-5ETG-4	.3125	.6875	.625	.255	.010	.418	.025	.010	.629	.010	.593	18	1	15	10,564	.03
HAB-6ET	HAB-6ETG	.3750	.9060	.813	.345	.020	.512	.025	.010	.840	.010	.781	23	1	15	18,881	.07
HAB-7ET	HAB-7ETG	.4375	1.0000	.875	.345	.020	.618	.025	.010	.934	.010	.875	21	1	15	21,302	.10
HAB-8ET	HAB-8ETG	.5000	1.1250	.937	.401	.020	.730	.025	.010	1.059	.010	1.000	19	1	15	28,326	.16
HAB-10ET	HAB-10ETG	.6250	1.3750	1.200	.567	.020	.856	.035	.020	1.279	.015	1.250	19	1	15	49,837	.25
HAB-12ET	HAB-12ETG	.7500	1.5625	1.280	.620	.030	.970	.035	.020	1.467	.015	1.375	18	1	15	60,013	.32
HAB-14ET	HAB-14ETG	.8750	1.7500	1.400	.625	.030	1.140	.035	.020	1.654	.015	1.531	17	1	24	67,810	.43
HAB-16ET	HAB-16ETG	1.0000	2.1250	1.875	.835	.030	1.278	.055	.020	2.000	.015	1.875	20	1	24	110,530	.83
HAB-18ET	HAB-18ETG	1.1250	2.3125	1.875	.942	.030	1.400	.055	.020	2.188	.015	2.062	20	1	24	136,957	1.10
HAB-20ET	HAB-20ETG	1.2500	2.5000	1.875	1.005	.030	1.523	.055	.020	2.375	.015	2.250	21	1	24	159,756	1.32
HAB-22ET	HAB-22ETG	1.3750	2.7500	2.125	1.097	.030	1.670	.055	.020	2.625	.015	2.500	22	1	24	194,078	1.80
HAB-24ET	HAB-24ETG	1.5000	3.0000	2.250	1.175	.030	1.800	.055	.020	2.875	.015	2.672	21	1	24	222,208	2.22



Timken Aurora Bearing Company | 901 Aucutt Road | Montgomery, IL 60538 U.S.A.

**PHONE: (630) 859-2030
FAX: (630) 859-0971
timkenaurorabearing.com
customerservice@aurorabearing.com**

The Timken team applies their know-how to improve the reliability and performance of machinery in diverse markets worldwide. The company designs, makes and markets bearings, gear drives, automated lubrication systems, belts, brakes, clutches, chain, couplings, linear motion products and related power transmission rebuild and repair services.

© 2024 The Timken Company